

# Product Handling

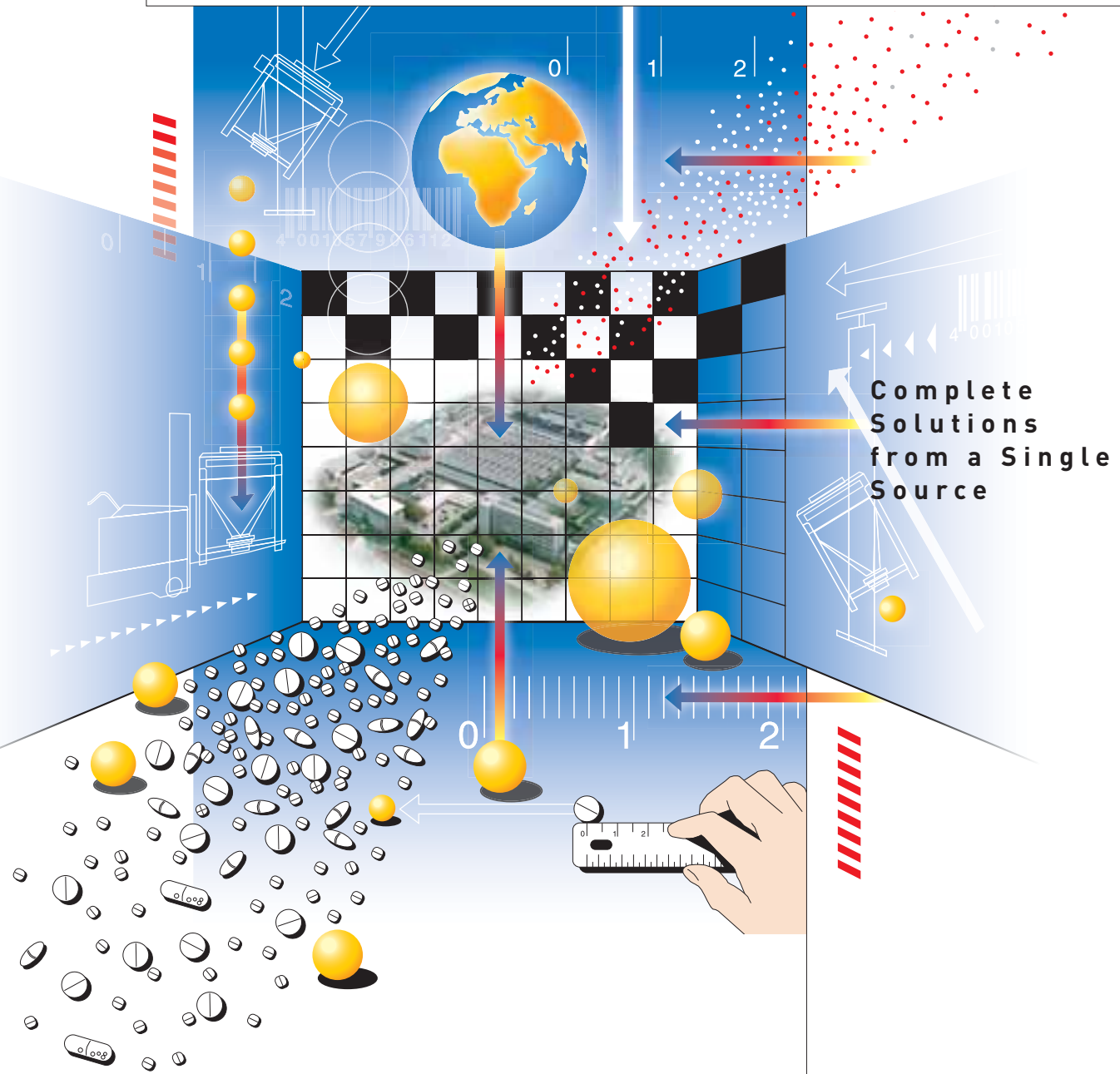

Complete  
Solutions  
from a Single  
Source

**Glatt**<sup>®</sup>

**We set  
the standard**

# Glatt Full Service

**Production and innovation. Everything from a single source.**

Over the past decades, Glatt has created a name for itself as a leading supplier of equipment in solid dosage fabrication for the pharmaceutical industry. Having started as a small-scale manufacturer of specialized machinery in fluid bed technology, Glatt has evolved into a worldwide group that comprises more than 20 diversified companies with more than 1500 employees.



Glatt built and installed the world's first fluid bed processor for industrial use in 1959



Fluid bed granulating and coating with a Glatt GPCG 300

## The logical step: Product handling

Product handling represents the link between the individual process steps. Glatt has recognized the growing importance of this link and established various new product lines that are custom-designed for the requirements of our clients and can be applied to a multitude of product handling tasks.

Glatt is capable of supplying an extremely wide range of system components, ranging from a single post hoist through to equipping a fully automated factory. Whether for weighing, dosing, mixing, sieving, transport, storage or docking, manual or automatic, Glatt offers the optimum solution for every requirement.



Ergonomic product handling with low dust levels



High-shear granulation with a Glatt VG 800 vertical granulator

Today customers want integrated systems – ideally from a single source. The main design criteria of a product handling system are determined by the material flow, the degree of automation and the level of containment.





Product handling from Dresden:  
Your potential for rapid growth and  
process optimization

**The planning phase -  
Laying the foundations for  
future success.**

It is during the planning phase that the foundations for future success are laid. As a result, Glatt not only offers individual components with full support right from the concept and planning phases – it is also possible to integrate existing systems and equipment into these overall concepts.

Glatt's experience is based on the successful completion of numerous major projects.

A high level of flexibility coupled with customer input provide the basis to meet all of our customers' requirements. Glatt is proud both of its ability to supply custom-made systems and equipment and of its skills in implementing complete turnkey solutions. Close cooperation with our customers from the start guarantees successful completion of the projects. Providing outstanding after-sales service is another part of Glatt's recipes for success.

**All  
production  
processes  
in the very  
best hands!**



**We set  
the standard**



# Vertical Material Flow Principle

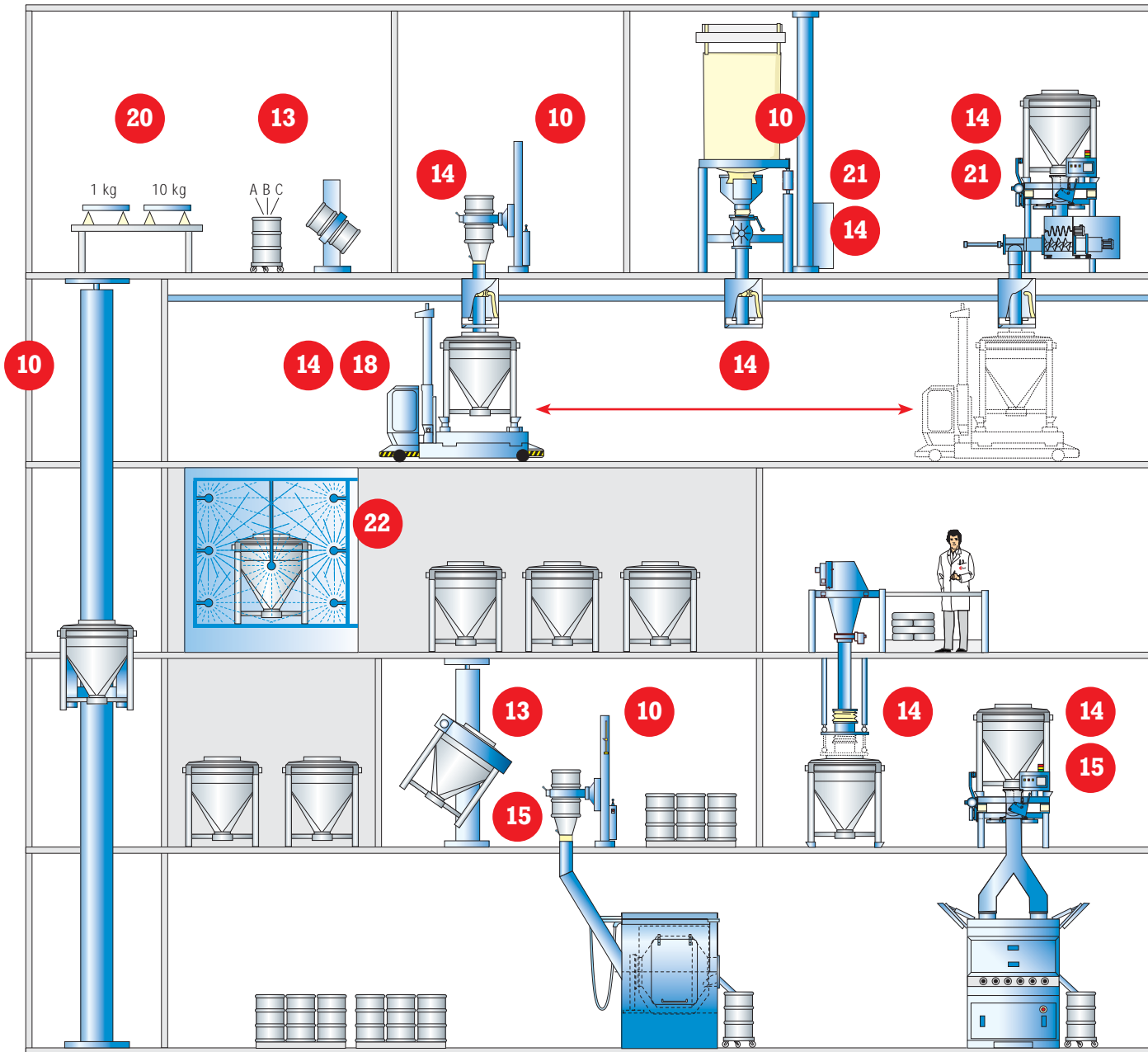

## Vertical processes on different levels.

The question of the basic process layout dominates the planning and configuration of how the main process steps (e.g. granulation, drying) are linked together by essential product handling operations.

The vertical arrangement involves having product flowing predominantly downwards through several levels driven by gravity. The individual process steps are either directly linked together or are interconnected by the use of Intermediate Bulk Containers (IBC) with docking stations for filling or discharging. Using IBCs and docking stations makes it possible to freely select the sequence of the various process steps.

**Quality down to the last detail through using high quality components.**

All Glatt handling components are manufactured to a very high level of quality. We offer advantages such as GMP compliant stainless steel construction, high functionality, and an easy-to-clean design. The use of certified pharmaceutical grade materials is standard.

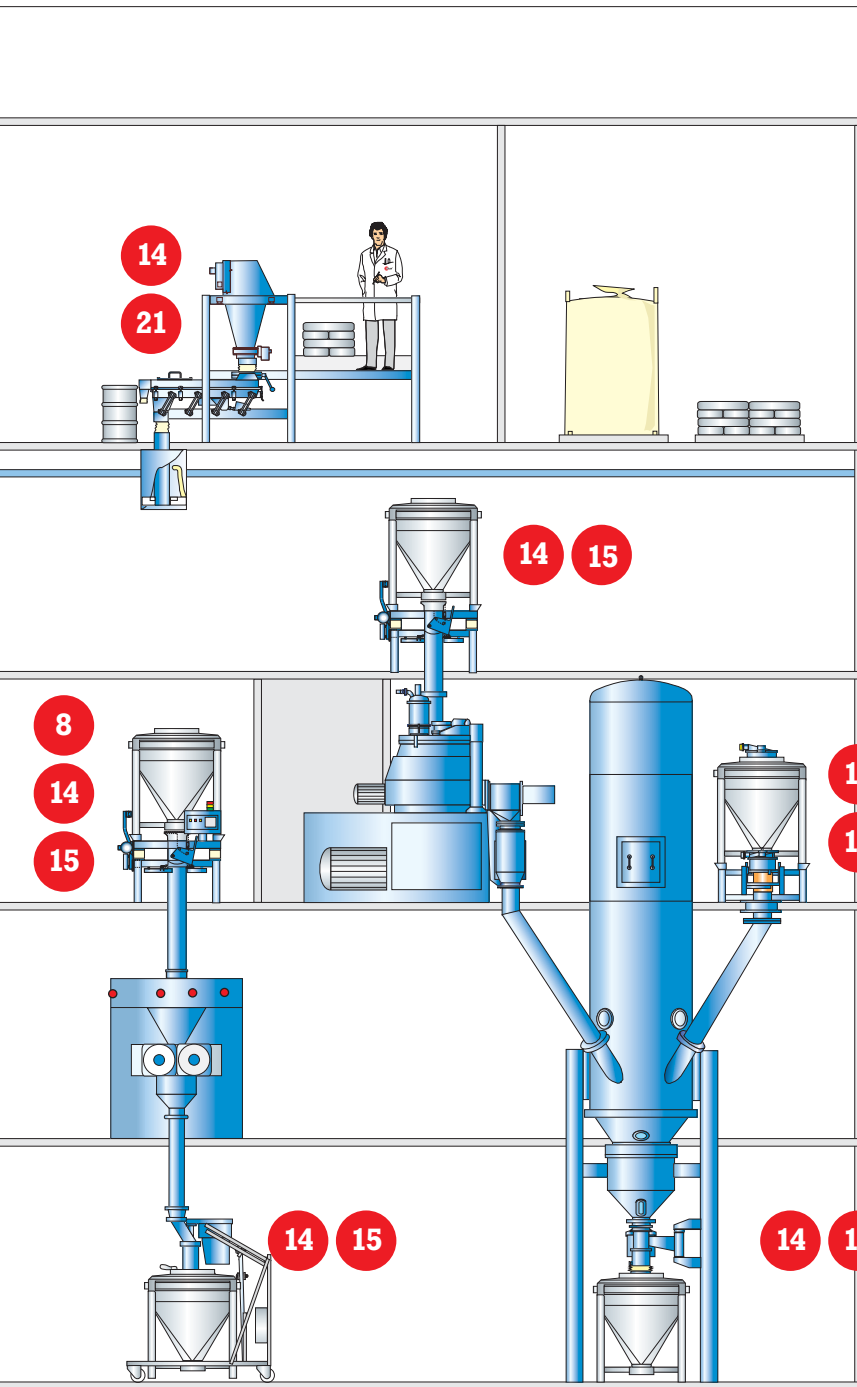

The high level of quality is guaranteed by our skilled work force and our demanding internal acceptance criteria.

**Customized according to personal requirements: The latest in control systems and data management.**

The scope of process control ranges from straightforward local manual operation through to complete process automation

using programmable logic controllers and PC systems. Furthermore, it is possible to integrate many different functions for recipe management, data acquisition and data monitoring via networks.



**We set  
the standard**

# Horizontal Material Flow Principle

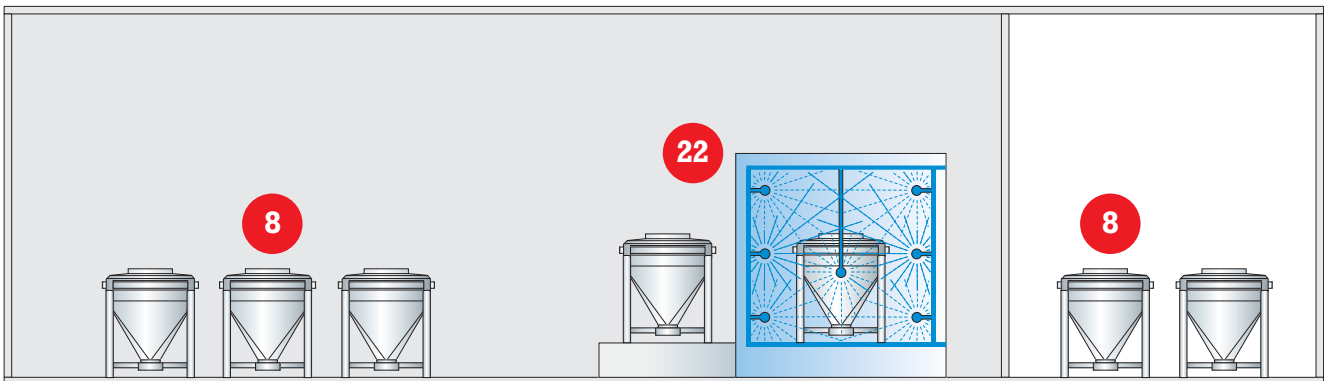
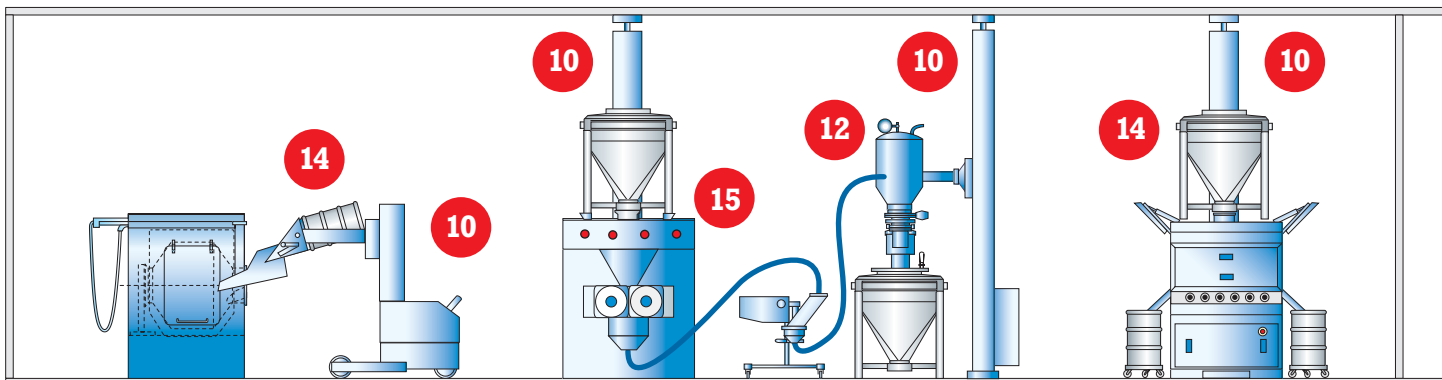
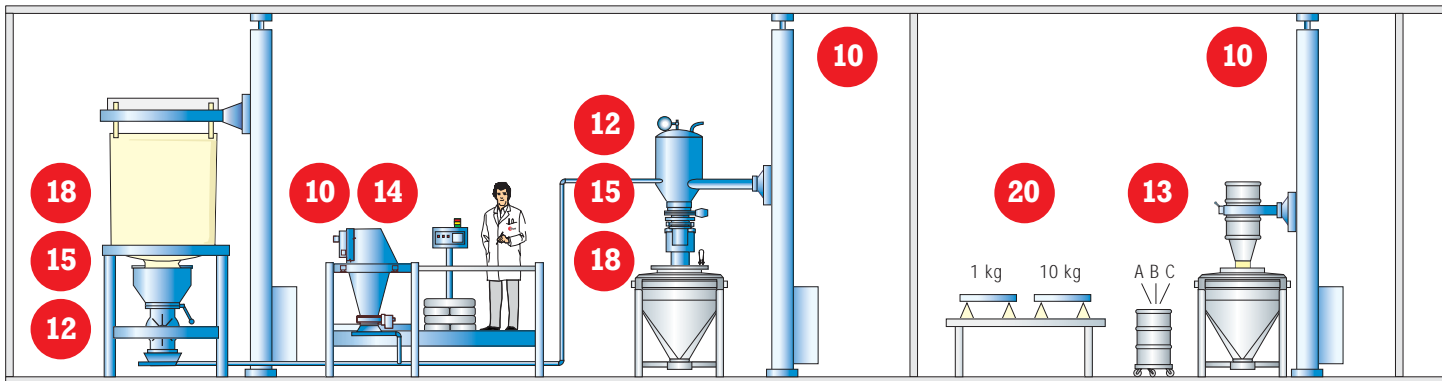

## Horizontal processes on one level.

In a horizontal process layout, both vacuum transport and / or gravity are used to induce product flow. Pneumatic conveying systems are used in many of these applications, as well as mobile and stationary lifting and discharging devices.

The flexibility provided by a horizontal arrangement of process components allows for rapid product changes and an infinite variety of process configurations.



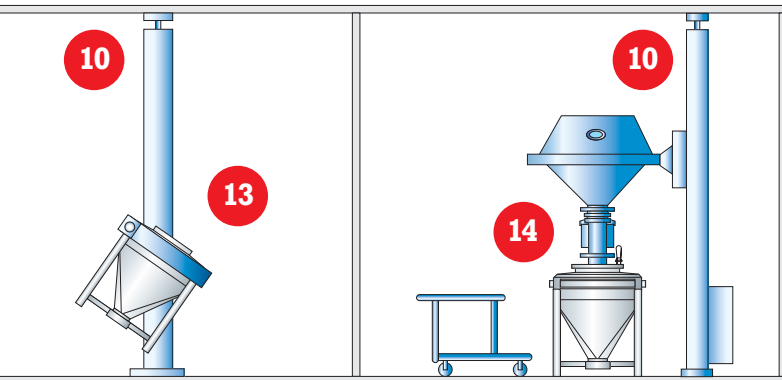
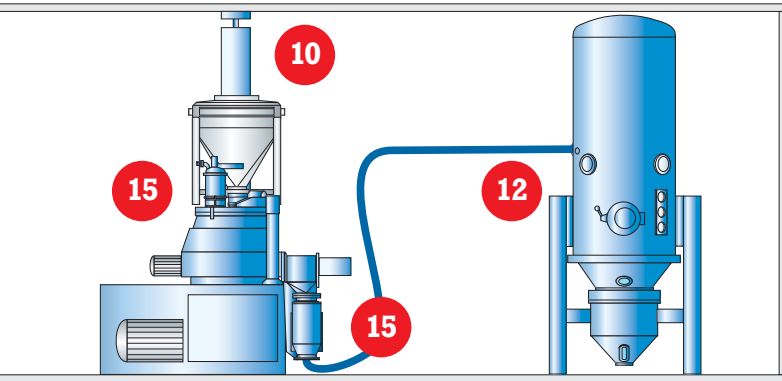

Glatt product containers in various shapes and sizes

## Contents

	Page
Glatt Full-Service	2
Vertical Material Flow Principle	4
Horizontal Material Flow Principle	6
Intermediate Bulk Containers	8
Lifting, Discharging and Transport Systems	10
Pneumatic Conveying Systems	12
Drum and Container Blenders	13
Filling and Discharging Systems	14
Docking Systems	15
Isolation Flap System SKS	16
Large Component Weighing Systems	18
Small Component Weighing Systems	20
Dosing Systems	21
Washing Systems	22
Data Management and Documentation	23
Addresses	24



**We set  
the standard**

# Intermediate Bulk Containers

**Effective.  
Practical.  
Flexible.  
Reliable transport  
of product and  
information.**

**W**eighing, mixing, storage, transport and documentation. Glatt offers a complete range of stainless steel containers for powders and granules, which are carriers for product and process information at the same time. The extensive range of containers includes a comprehensive range of cross sections - rectangular, square or round.



Round container type CR 200 on transport frame

**All options are available, according to the particular application:**

- Stacking capability
- Fork channels
- Skids for roller conveyor transport
- Filling lid
- Quick release
- Filter
- Discharge flaps
- Discharging supports
- Gas blanketing system
- Batch documentation



Computer-aided container weighing system



Secure information flow using barcode identification on the container



Electronic data transfer via MOBY chips

**Containers can be supplied as self-supporting structures or with a rigid frame, depending on the specific requirements.**





# Intermediate Bulk Containers

The Glatt Intermediate Bulk Containers has proved its value as a systematic link between the individual process steps.

## Standardization through modular design.

Based on the close co-operation with our customers and on years of experience Glatt has developed a standardized modular design concept for IBCs.



Glatt product containers in various shapes and sizes



CS 3000 product container

Technical data on request!

# Lifting, Discharging and Transport Systems

**Lifting.  
Positioning.  
Transport.  
Turn and rotate  
as needed.**

Glatt boosts the efficiency and mobility of your handling systems! We provide a range of equipment for modern and effective product handling. This range includes a great variety of mobile and stationary lifting and discharging devices.

The classic applications are:

- Simple horizontal or vertical transport
- Positioning for filling and discharging of containers, drums, big-bags (super sacks), and product bowls for fluid bed machines
- Positioning of equipment (e.g. sieves, pneumatic conveying systems)



Drum discharging in longitudinal direction using EL 600 stationary lifting device



L 1500 lifting device for discharging containers into a VG 600 vertical granulator



LD 120 stationary lifting and discharging device



Lightweight lifting device type MEL 300



EL 250 RH mobile lifting device for discharging of drums

## Mobile or stationary – It's your choice.

Glatt offers a wide range of equipment to meet any requirement. The standard product line includes stationary lifting equipment with payloads up to 2500 kg as well as mobile lifting and transport equipment with up to 1200 kg payload.



L 1200 TS mobile, battery operated lifting device

# Lifting, Discharging and Transport Systems

Glatt always finds a solution to save on costs and time, no matter how tricky the task. Standardized. Yet compatible with a wide range of handling equipment.

If door heights are a restriction, mobile lifting devices with telescopic columns provide a convenient solution.

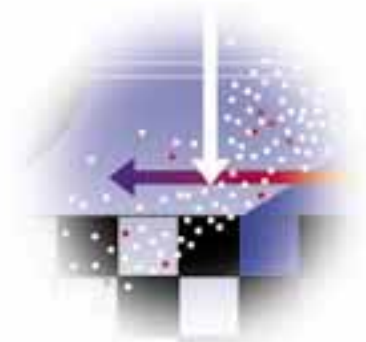

Mobile drum inverter MEL 300 with discharging cone and DN 100 flap

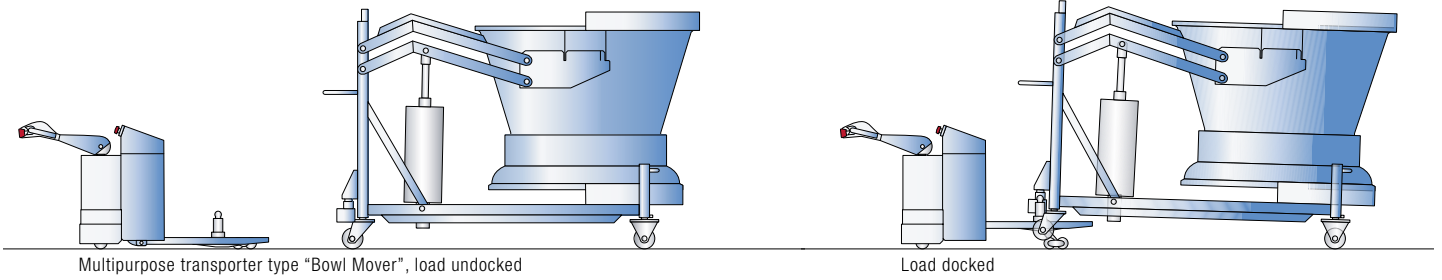

Technical data on request!

# Pneumatic Conveying Systems

**Vacuum transport.**  
**Flexible.**  
**Direct linkage of processes.**

Glatt PCS pneumatic conveying systems make it possible to transport powders, granules and other free-flowing solids by means of negative pressure, handling the substances gently.

Glatt PCS systems can be used wherever process units and product carriers are filled and emptied. The same applies to direct transport between two process steps, especially on the same level. The pneumatic conveying systems are equipped with filters on the exhaust air side.

Glatt PCS pneumatic conveying systems available in 9 different sizes: from the PCS 10 up to the PCS 900 - these sizes refer to the nominal volume of the product separator in dm<sup>3</sup>. In addition to the standard PCS line the pneumatic conveying systems are also available as version SC-Super-Clean (Clean in Place CIP) and PRO (12 bar pressure shock resistant) in the same sizes.

The pneumatic conveying systems can operate in connection with further equipment in both modes - batch or quasi-continuous.



Pneumatic conveying system PCS-Pro 50, 12 bar pressure shock resistant



Separator of a PCS-PRO with swiveling lid for an easy filter exchange

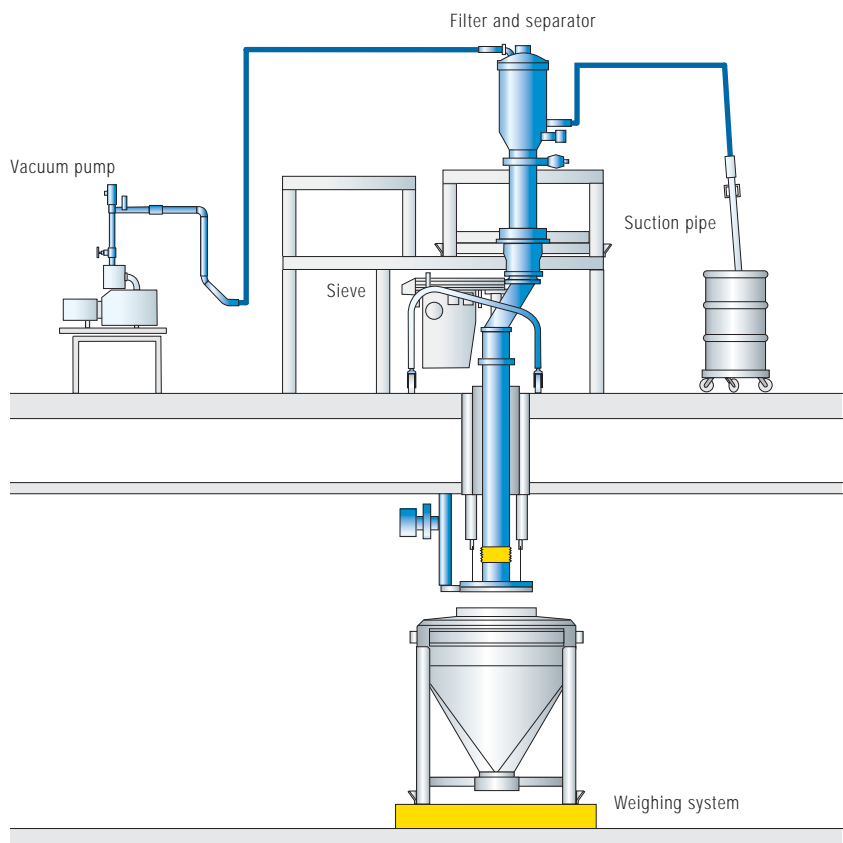

Pneumatic conveying system with separator module for IBC charging





# Drum and Container Blenders

**Thorough mixing.  
Homogenizing.  
Ideal distribution  
of active  
ingredients  
and additives.**

In the processing of powder and granules, batch blending represents an important process step. Through storage, transport or weighing - all the active ingredients, additives and raw materials in the IBC have to be converted into a homogenous mixture as quickly and effectively as possible.

**Glatt has an appropriate ATEX conform blender for all requirements, whether for containers and drums. All Glatt blenders are easy to integrate into process lines and quick and simple to load. Furthermore all Glatt blenders operate quietly thanks to their pneumatical and mechanical clamping devices.**



KCM 800 container blender

### KCM container blender series

- For rectangular / square IBCs from 150 l to 1.600 l
- For drums up to 200 l
- Low-noise blending process through reliable fixing of IBCs by means of mechanical clamping or for drums, using manual or mechanical clamping
- Quick tilting of the IBC or drum into blending position
- Rapid blending results through an optimum positioning of IBC or drum
- Constant speed and direction of rotation



CM 1000 container blender

### CM container blender series

- For rectangular / square IBCs from 250 l to 2.000 l
- Low-noise blending process through reliable fixing of IBCs by means of inflatable seals
- Rapid lifting of the IBC into the blending position
- Ideal, thorough mixing by rotating the IBC in its clamping arm and having a product flow diverted by the IBC corners
- Variable speeds and directions of rotation on the IBC
- Combining the advantages of the lifting device and IBC blender
- Suitable for additional process steps (e.g. sieving & milling)



CMR 1000 container blender for round container

### CMK container blender series

- For rectangular / square IBCs up to a capacity of 3.000 l
- Low-noise blending process
- IBCs are loaded into a blending cage and fixed safely by mechanical clamping drives
- Ideal and thorough, by having a product flow diverted by the IBC corners
- Variable speeds and directions of rotation on the IBC



CMK 1000 special design, mixing between two columns



Tilting blender for drums up to 200 l

### CMR container blender series

- For container with round cross sections from 400 l to 1.500 l
- Low-noise blending process by a special IBC clamping on the top
- Ideal blending without additional mixing devices
- Simultaneous biaxial rotation of the IBC at different speeds
- Reduced handling and cleaning work

# Filling and Discharging Systems

**Reliable.  
Low-contamination.  
Flexible.  
The optimum  
solution for every  
process.**

Glatt filling and discharging devices are always in demand when powdery substances have to be transferred into IBCs or process units without creating dust. As such, protecting people and safeguarding against cross-contamination are the most important priorities.

## Modular systems make up the complex solution

With its modular filling and discharging systems, Glatt is in the best possible position to meet the individual customer requirements.



Discharging station, universal for containers and big-bags



Container discharging station above a tablet press

### Filling / Discharging

- Batch identification
- Verifying the batch weight
- Status check of the unloading and receiving system
- Seamless process documentation
- Quick and easy:  
Equipment change – Docking – Cleaning



Contamination-free discharge of IBCs using the SKS isolation valve system



Discharge station, docking under the FBE with bottom discharging



Pneumatical discharge of big bags for ready-made packaging



# Docking Systems

**Low dust levels.**  
**Safe.**  
**Reliable.**  
**Manual and automatic.**

**Clean filling and discharging with minimum dust.**

As a rule, the following docking elements are used for filling and discharging of product receptacles and process systems:

- Silicone collar, tulips and compensator for pipe ends and flanges
- Static seal with docking / lifting device
- Contact-free docking system
- Inflatable radial and axial seal
- Docking with isolation flap system (see page 16)

Dust must not escape into the environment during the filling and discharging of powders and granules. As a result, docking devices which operate with total reliability are essential in terms of low-dust product handling. All docking elements have been developed by Glatt in accordance with the required "level of containment".



Docking system using an inflatable axial seal, after docking

## Charging

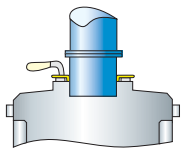

Silicone collar with adapter pipe

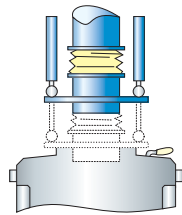

Static seal with pneumatic lifting device

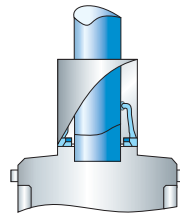

Contact-free docking system

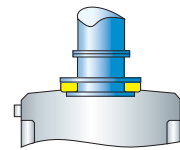

Inflatable radial seal

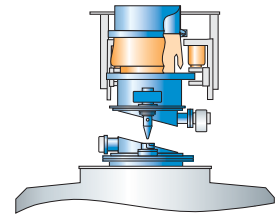

Glatt isolation flap system SKS

## Discharging

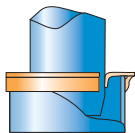

Silicone collar

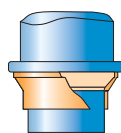

Tulip shaped docking collar

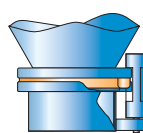

Inflatable axial seal

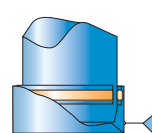

Inflatable radial seal

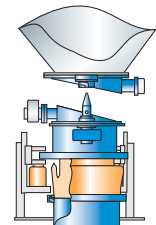

Glatt isolation flap system SKS

## Perfect solutions.

Additional components which complete the docking system and contribute to operation with minimum dust include: positioning elements, ceiling pass through elements and local dust exhaust systems, self-cleaning chute covers and various cleaning accessories. Glatt offers all these elements with our standard level of high quality.



Docking system using an inflatable radial seal, before docking



Docking system using an inflatable radial seal, after docking



# Isolation Flap System SKS

**Ecological.  
Economical.  
Automatic.  
Patented total  
containment  
solutions.**

Highly potent substances require highly effective protective measures for human being, environment and product. The Glatt SKS isolation valve system sets new standards in the containment transfer and is since several years a worldwide industry-proven technology.

**The SKS system operates in the following sequence:**

- 1 Positioning of the IBC on the docking station
- 2 Docking of the active valve to the passive valve
- 3 Aligning of the valve halves to each other by means of centering / locking pins
- 4 Locking both halves by rotating the centering / locking pins
- 5 Opening the valve
- 6 Product transfer
- 7 Internal air purging of the seal surfaces
- 8 Closing the valve after filling / discharging
- 9 Unlocking both valve halves
- 10 Removal of IBC from the docking station

**A complete set-up for integration into a docking station consists of:**

- One active valve incl. pneumatic actuators for locking and opening / closing of the valve
- One docking module incl. float-mounted system and connecting product chutes to the filling / discharging equipment
- One PLC control system, controlling the docking and opening / closing sequences of the valve

## Flap system SKS

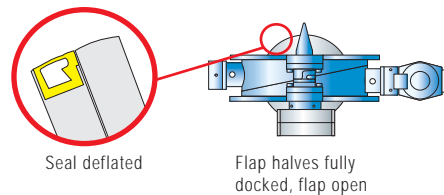
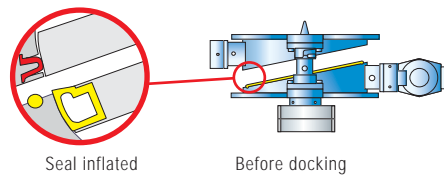

Docking sequence

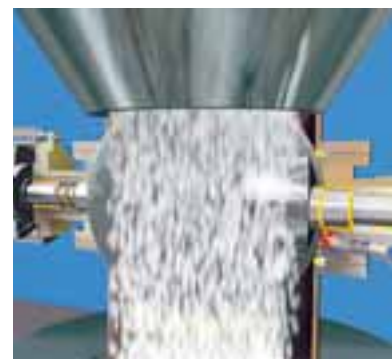

Product transfer

**The Glatt Isolation Flap System SKS.  
Definitely the best solution for Total Containment.**



IBC discharge using the Glatt SKS isolation valve system



# Isolation Flap System SKS

## The SKS system offers the following advantages:

- Full operator protection
- No cross-contamination
- No product contamination
- Economical through dispensing with secondary measures (e.g. clean room, operator protection clothes)
- Reproducible containment levels over long periods
- Quick docking and undocking cycle (< 10 seconds)
- Completely WIP-capable
- Safe pre-moistening via WIP before opening the containment system
- Extremely low-wear operation because no mechanical contact between disk and housing
- Quick and easy disassembly / reassembly for cleaning / inspection
- Flexible, manual and fully automated operation possible

## Technical data

### Nominal sizes:

DN 100, DN 200, DN 250.  
Other sizes on request.

### Material / surface finish:

Stainless steel AISI 304 / 316.  
External surface: Glass bead blasted.  
Surface in contact with the product: Fine turned / mirror polished.  
Other materials and surface qualities on request.

### Seals:

PTFE for passive SKS flaps,  
silicone rubber for active SKS flaps.  
Other sealing materials on request.

### Drives:

Pneumatic drives for flap actuation and housing interlocking.  
Manual flap actuation and housing interlocking.



Pneumatic drive for interlocking

### Control system:

Proximity switches for monitoring the docking position, interlocking, seal function and flap position.  
Can be fully integrated into master control systems.

### Cleaning:

Flap components with inflatable seal following straightforward dismantling / mounting.  
Flap components with static seal in installed condition.



Operator terminal



Manual and easy dismantling



Washing station for IBCs with passive valves

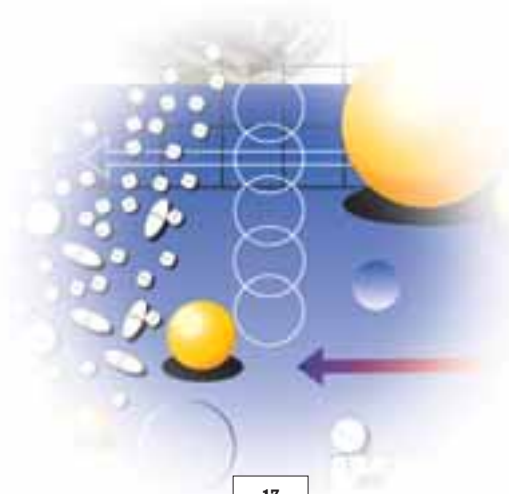

# Large Component Weighing Systems

**Productive.  
Product line oriented.  
Safe and flexible.  
Manual or automatic raw material weighing.**

The raw materials required in large quantities are added to the process from storage receptacles such as big-bags (super sacks), sacks, drums and cardboard boxes. This may involve direct addition to the process system or it can be indirect, with prior dispensing into IBCs. In this process, in most cases, large quantities of several raw materials are weighed and added to the batch container or drums at short intervals with an adequate degree of accuracy.



Weighing system incl. dosing

The different process equipment available includes everything from manually operated single weighing stations through to fully automated weighing systems. Glatt also offers full solutions for every application in this case.



AGV for automatic weighing and charging of IBCs

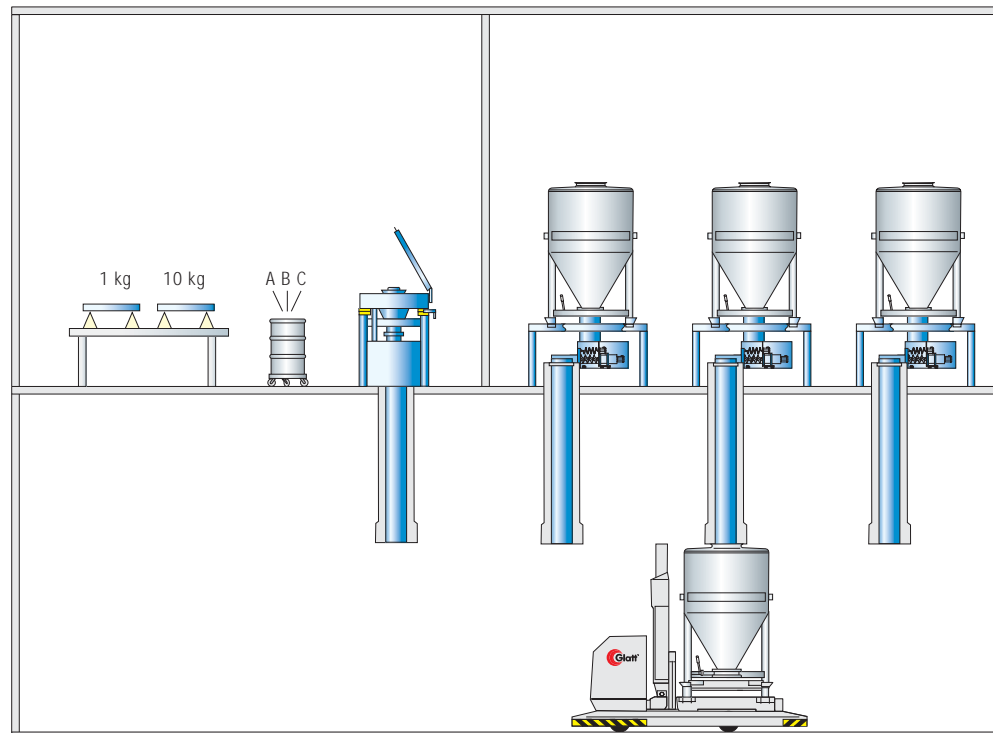

Automatic weighing line, direct discharge from packings or dispensing by IBCs

# Large Component Weighing Systems

## Weighing systems

- Very high level of safety for operators and the product
- Automatic weighing with high productivity
- Incorporation of adding stations for "pre-mix" and small components
- Raw material identification and verification
- Recipe management
- Interface to production management system
- Automatic process and batch documentation



Raw material dispensing from sacks, big-bags (super sacks) and IBCs

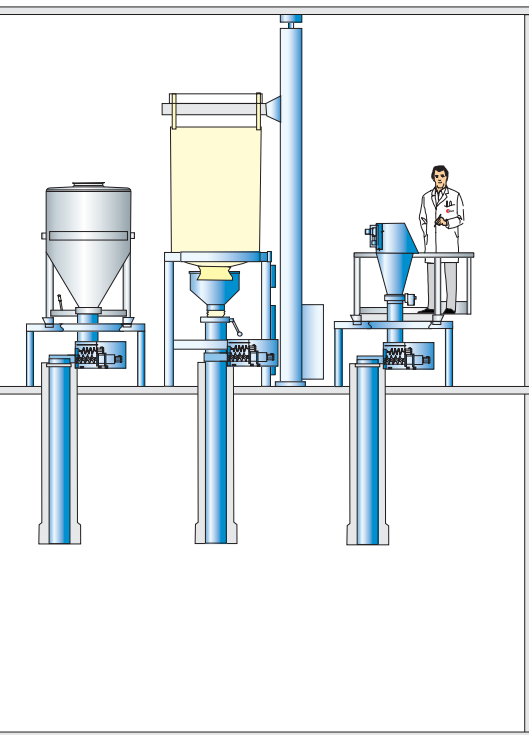

Manual weighing-in of active ingredients

## Weighing stations and cabins

- Manual with high precision
- Direct weighing from packings
- Weighing log / manual process documentation
- Safety check for raw materials
- Operator information from the production management system



# Small Component Weighing Systems

**Precise.  
Reproducible.  
Safety for the  
operator.  
High containment  
level thanks to  
laminar flow or  
glove boxes.**

The increasing complexity of formulations is leading to a situation in the powder and granule processing industry whereby more and more constituents comprising small quantities of active ingredients, additives, colorings, etc. have to be added to the base carrier materials.

All batch information is checked carefully before each weighing procedure. The documentation is prepared after the weighing process. Glatt offers compact and easy-to-use small component weighing systems for different weighing ranges and tolerances.



Charging station for small packings

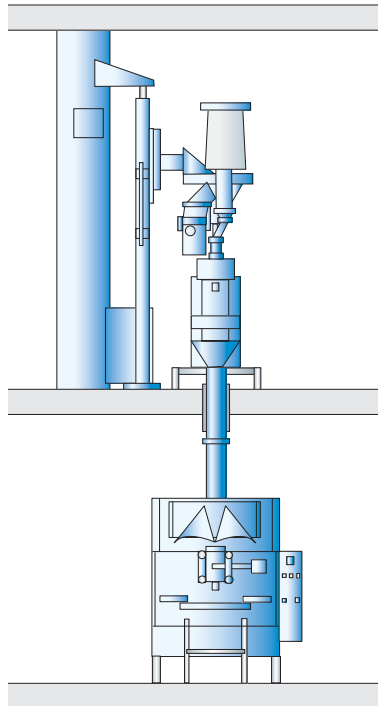

Automatic weighing and filling system for small portions into plastic bags



Manual checking of pre-weighed ingredients at weighing station

## Adding active ingredients and additives to containers

- Rapid product change thanks to replacement of parts which come into contact with the product
- Exact product identification and checking
- Display and activation of safety functions in case of deviations
- Adding to the container in "pre-mix" format or as active ingredients / additives



Weighing cabin for small components

## Manual weighing in cabins

- High precision
- Operator protection
  - by laminar flow
  - separate handling in a glove box
- Exclusion of cross-contamination by simple cleaning of the rooms and equipment
- Weighing of UV-sensitive and hygroscopic products
- Exact product identification and checking
- Automatic / manual documentation of the weighing operation

## Semi-mechanized weighing of larger quantities

- High precision by manual dosing
- Combination of manual and mechanized weighing
- Rapid weighing of large quantities of active ingredients
- Solutions adapted to the product
- Exact product identification and checking
- Automatic / manual documentation of the weighing operation
- Mixing of the active ingredients and additives in "pre-mix" stations

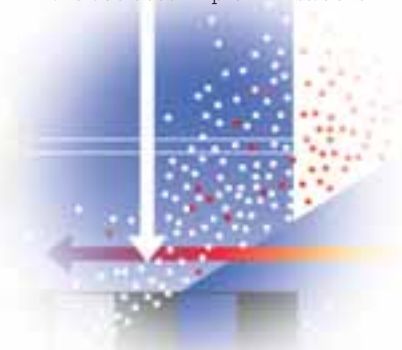



# Dosing Systems

**Safe.  
Clean.  
Accurate.  
With maximum  
precision.**

Glatt offers a wide range of dosing devices for low dust and, if required, automated dosing into transport and storage product receptacles as well as into process systems. The dosing range for powders and granules extends from a few grams to several thousand kilograms per hour, with the usual high level of precision. The guaranteed dosing accuracy forms the basis for sustained repeatability in recipe formulations. Glatt also uses commercially available dosing systems from other manufacturers.

## Rotary feeder (ZRS)

- Defined barrier to process steps
- High level of dosing accuracy (depending on the individual chamber volume)
- Fine dosing by single chamber indexing
- Design with almost no gap minimizes dosing errors



Rotary feeder, with practically no gap, for even dosing and filling

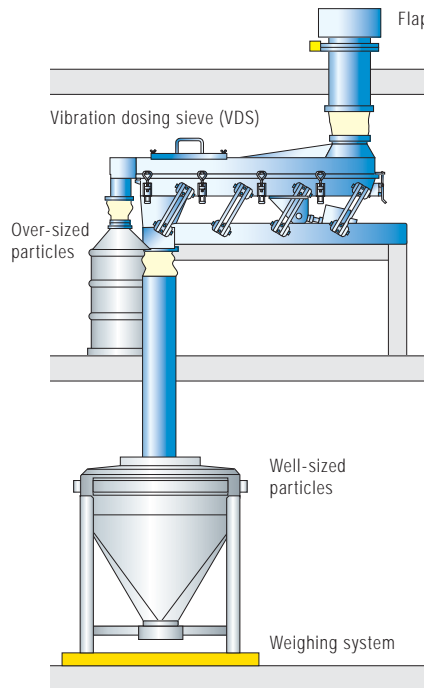

Dosing system with integrated vibration dosage sieve



Vibration dosing sieve, integrated in a discharge station for big bags (supersacks)

## Vibration dosing sieve (VDS)

- Dust-free separation of foreign particles (e.g. wood and metal chips, etc.)
- Homogenization of product
- Throughput levels from a few cm<sup>3</sup> per hour to several m<sup>3</sup> per hour
- High dosing accuracy (depending on size and product)

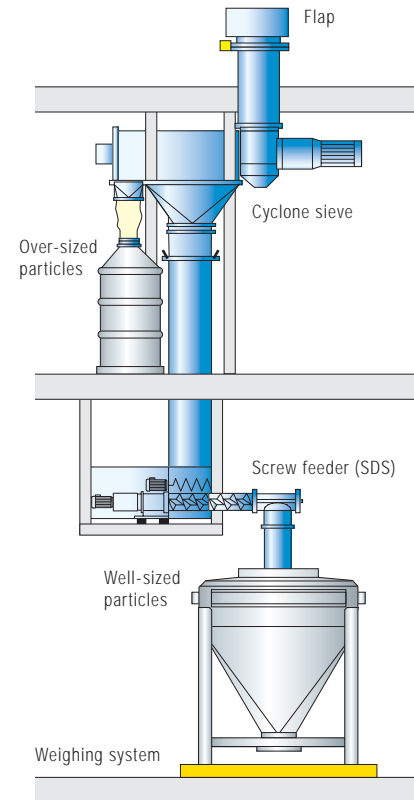

Dosing system with integrated cyclone sieve and a dosing screw



Mobile SDS feeder, docked

## Screw feeder (SDS)

- Consistent dosing and product transport
- Throughput levels from a few cm<sup>3</sup> per hour to several m<sup>3</sup> per hour
- High dosing accuracy (depending on size and product)



# Washing Systems

**Washing.  
Drying.  
Cooling.  
Product-specific  
with clean  
solutions.**

**M**anual or fully automatic washing? The trend in cleaning process systems is increasingly moving in the direction of fully automated cleaning. As a result, Glatt has developed special solutions for the cleaning of IBCs. These solutions can be adapted to the specific technical and structural conditions. The variety of systems ranges from a simple manual washing station up to validated, fully automatic washing, drying and cooling stations built as single or multiple cabins together with the associated preparation systems for washing solutions.

## Single cabin washing systems

- Washing, drying and cooling in one cabin
- Up to 8 containers per shift
- Flaps open and close manually / automatically in the cabin
- Automatic selection of washing recipe based on the container ID
- Washing recipe management and washing process documentation



CIP rack for preparation of washing recipes



Automatic double cabin washing machine with IBC loading and removing stations



Washing nozzle

## Multiple cabin washing systems

- Washing and drying / cooling in separate cabins arranged one after the other or side-by-side
- Up to 20 containers per shift
- Automatic container transfer
- Flaps open and close manually / automatically in the cabin
- Automatic selection of washing recipe based on the container ID
- Washing recipe management and washing process documentation

## Supply units for washing systems

- Washing solution recipe and washing cycle can be determined according to the last product in the container
  - Provision of solution for pre-cleaning
  - Provision of deionized water (warm or cold)
  - Provision of washing solution
  - Preparation of media inside the machine or by the customer

# Data Management and Documentation

**Automation.  
Validation.  
Documentation.  
Secure and  
reliable data  
management.**

The increasingly demanding requirements for control, monitoring and data management systems are determined by regional and company-specific ordinances, rules and standards.

The specialists at Glatt develop, plan and supply complete control and information system packages specifically tailored to the customer's requirements. The increasing demand for processes to be reproducible is making it necessary to document all processes and equipment and to prepare all relevant data within a logical structure.

**The modern data acquisition and documentation system from Glatt helps customers to address their planning and production tasks. Process data such as recipes and operating data for machines and plants can be automatically uploaded and evaluated.**



Validation and Documentation



Qualified training programs

## Documentation of product and process data

### Manual

- Input via keyboard
- Scanning of barcodes using a hand-held scanner
- Confirmation of inquiry routines by the operator
- Printout on a document printer
- Printout on a barcode label printer

### Automatic

- Scanning of barcodes using a machine scanner
- Downloading electronic data from MOBY
- Uploading electronic data onto MOBY

## Validation stages and support

- **Design qualification (DQ)**  
Specifications and test schedules according to the customer's requirements
- **Installation qualification (IQ)**  
Completeness of equipment and correct installation
- **Operation qualification (OQ)**  
Correct function of the equipment and function of the system in defined working areas
- **Performance qualification (PQ)**  
Reliability of equipment



Glatt offers regular courses on specific topics in its in-house Technology Center

**All  
production  
processes  
in the very  
best hands!**



**We set  
the standard**





## Addresses



### **Glatt Systemtechnik GmbH**

Grunaer Weg 26  
01277 Dresden / Germany  
Phone: +49 351 25 84 0  
Fax: +49 351 25 84 328  
eMail: info@glatt-dresden.de



### **Glatt Norden ApS.**

Skøjtevej 27 - 31  
2770 Kastrup / Denmark  
Phone: +45 48 14 22 44  
Fax: +45 48 14 22 55  
eMail: info@glattnorden.dk

### **Glatt Pharmatech SASU**

Parc Technologique  
6, rue Louis Néel  
21000 Dijon / France  
Phone: +33 3 80 74 32 64  
Fax: +33 3 80 74 43 95  
eMail: info@glatt-pharmatech.fr

### **Glatt Protech Ltd.**

Swannington Road  
Cottage Lane Ind. Est.  
Broughton Astley  
Leicester LE9 6TU / Great Britain  
Phone: +44 1455 28 58 58  
Fax: +44 1455 28 55 10  
eMail: info@glatt-protech.co.uk

[www.glatt.de](http://www.glatt.de)

**Glatt  
customer service  
worldwide**



### **Glatt GmbH Process Technology**

Werner-Glatt-Straße 1  
79589 Binzen / Germany  
Phone: +49 7621 6 64 0  
Fax: +49 7621 6 47 23  
eMail: info@glatt.de



### **Glatt Maschinen- & Apparatebau AG**

Kraftwerkstrasse 6  
4133 Pratteln 1 / Switzerland  
Phone: +41 61 8 26 47 47  
Fax: +41 61 8 26 48 48  
eMail: info@glatt-ag.ch



### **Glatt Air Techniques Inc.**

20 Spear Road  
Ramsey, NJ 07446 / USA  
Phone: +1 201 8 25 87 00  
Fax: +1 201 8 25 03 89  
eMail: info@glattair.com



### **Glatt Ingenieurtechnik GmbH**

Nordstraße 12  
99427 Weimar / Germany  
Phone: +49 3643 47 0  
Fax: +49 3643 47 12 31  
eMail: info@glatt-weimar.de



**We set  
the standard**